

# WALKERJET

## USER MANUAL „W“ ENGINES

### TECHNICAL SPECIFICATIONS

	W 100	W 130	W 200
Type	Single cylinder air cooling	Single cylinder air cooling	Single cylinder air cooling
Displacement	100 cc.	130 cc.	200 cc.
Power	18 hp	22 hp	27 hp
Max. rpm	10.000	8.200	7.500
Bore	54 mm	56 mm	66 mm
Stroke	45 mm	56 mm	56 mm
Reduction	3,5 - 3,8	3,1 - 3,5	2,5 - 3,1
Weight complet	11 kg	13 kg	14 kg
Carburettor	Walbro	Walbro	Walbro
Ignition	Electronic	Electronic/ Processor CDI	Electronic/ Processor CDI
Starter	Manual	Electric	Electric

The Walker jet engine is designed to function with a GASOLINE/OIL mixture.

We recommend using full-synthetic based oils. During the running-in stage, use an oil percentage of 3%, and then 2% once this stage has been completed. The gasoline must have an octane number taht is not lower than 95, in order not to run into pre-ignition phenomena.

Carefully mix the gasoline with the oil in a suitable can. It is advisable, once they have been mixed, to use the mixture within a month.

Do not use the vegetable or animal oil.

**DO NOT MIX DIFFERENT TYPES OF OIL TOGETHER.**

### CARBURETOR

The Walbro 37 carburetor, if used correctly, provides excellent performance, requiring few tuning interventions. In any case, changes in climatic and height conditions can affect functioning.

The carburetor is adjusted during the testing phase with a standard setting:

Screw H „affects the entire range of use of the engine“. From completely tightened, loosen by 1 turn or „360°“.

Screw L „only has an effect at a low engine speed“. From completely tightened, loosen by  $\frac{3}{4}$  of a turn or „270°“.

The carburetor is provided with a depression pump to remove the fuel from the tank. The gap between the two must not exceed 50-60cm. The same applies to the tube, which must not exceed 50-60cm.

It is advisable to insert a manual pump between the tank and the carburetor, so that the mixture can reach the carburetor before the start-up, therefore avoiding stressing the starter motor.

## CARBURATION

N.B. In this paragraph the term „MIXTURE“ refers to the combination of the two elements: (air) + (oil\gasoline) that takes place inside the carburetor.

Changes in atmospheric conditions and height affect the functioning of the engine, in that they vary the density of the air, as a result the air\oil\gasoline mixture ratio is modified.

As a general rule, we can say that a high altitude, high humidity or high temperatures, less air enters, and as a result the mixture is richer in „oil\gasoline“, so the correct ratio must be re-established by tightening the two „H\L“ screws.

On the other hand, at low temperatures and low humidity, the denser air makes the mixture lower in oil\petrol; as a result the two „H\L“ screws must be loosened.

## WARNING !!!

A mixture that is too low in oil\gasoline causes considerable damage to the engine, which can cause it to break down and/or stop suddenly.

It is recommended to carry out the carburation operations with the ENGINE SWITCHED OFF!

When the “H\L” screws are tightened\loosened, carry out variations of  $\frac{1}{8}$  of a turn each time or “45°”, larger movements in one turn can cause damage to the engine.

## WARNING!!!

- before starting the engine, ensure that there are no loosened screws or improperly attached parts.
- Ensure that any people are at a safe distance and never in the range of the propeller.
- Do not start the engine if there are any stones or other objects nearby, as they could be picked up and thrown large distances by the force of the propeller.
- Do not start the engine without a propeller.
- Do not start the engine in enclosed spaces, as the exhaust gases contain carbon monoxide, which is toxic and can cause loss of consciousness and death.

Before sale, the engines undergo pre-running-in, to check the correct functioning, and a test confirms all the advertised specifications.

Once you have acquired the W130, W200 you must pay particular attention during the first hour of functioning, in order to maintain all the engine`s qualities over time.

### WARNING!!!

DURING THE RUNNING-IN PHASE KEEP THE EXHAUST GAS TEMPERATURE AND HEAD TEMPERATURE UNDER CONTINUOUS OBSERVATION.

After having chosen a suitable place, above all without any stones or other material that could damage the moving parts, start the engine, leaving it to warm up for 10 minutes to approx. 2,500 rpm.

Then slowly bring the engine to a higher speed, decreasing and increasing the rpm at intervals of 1 minute, using various "ranges" of use, but without exceeding 4,500 rpm.

Continuous and repeated closing/opening of the gas valve must be absolutely avoided.

Approx. 20 minutes after switching on the engine, switch it off and leave it to cool down completely.

WARNING!!! When running and also after switching off, the engine can cause burns, therefore ensure that it has completely cooled down before working on it.

Carry out a careful visual check for any faults or loosened parts.

Having checked that everything is working properly and that there are no problems of any kind, repeat the previous operations with 20 more minutes of running-in, following the same instructions.

This time it is possible to space it out for the entire range of use of the engine, bringing it several times to the maximum speed at intervals of 1 minute.

Once 20 minutes have passed, turn the engine off.

When it has cooled down, carry out a complete tightening of all the engine screws. Now the engine is ready for the use it was designed for. Continue to use 3,5% oil for the next 10 hours.

Every time that the engine is used, routine pre-start-up checks must be carried out:

- Check that the silent blocks are completely intact.

## FUEL

- Check that the exhaust pipe does not have any cracks.
- Ensure that the propeller is not cracked or dented.
- Ensure that there is enough fuel, depending on the desired usage duration of the engine.
- Check that the electrical system and cables do not have any abrasions or breaks.
- Check that there are no loosened screws or components.

## BELT TENSION

### WARNING CARRY OUT THE OPERATIONS WITH THE ENGINE SWITCHED OFF AND COOLED DOWN

During Running, the belt is subjected to traction and wear, and as a result, lengthening occurs, which could lead to sliding on the pulleys, with a subsequent decrease in the general engine performance. To correct the tension, with a torque wrench, loosen screw M8 on the foot of the engine, which fastens the pulley can, turn screw M12 anti-clockwise using a force of 1,8 kgm and then re-tighten screw M8.

### INTERVENTIONS TO BE CARRIED OUT EVERY 20 HOURS

- Clean the carburetor filter.
- Clean the petrol filter.
- Check the belt tension and condition.
- Lubricate the ball joint on the catalytic converter.

### INTERVENTIONS TO BE CARRIED OUT EVERY 60 HOURS

- Replace the engine and exhaust pipe silent blocks.
- Replace the transmission belt.
- Check the condition of the rubber induction manifold.
- Replace the exhaust pipe sound-absorbent material.
- Check the distance of the spark plug electrodes if is greater than 0,9mm replace the spark plug.
- (Rubber components, i.e.: transmission belt, silent blocks, induction manifold, depression tube: may become damaged by atmospheric agents, therefore their duration over time may be different to that shown. The condition must therefore be checked and possible replacement may be necessary before the established time.

Description	Torque Nm
Head nut	22
M 6 Screws	12
M 8 Screws	24
Vacuum-operated screws	10
M 8 Nuts	25
M 12 Nuts	50
Spark plug	18

## WORKING TEMPERATURE

The engine W200 was designed to work at certain working temperatures, please carefully adhere to the following. Temperatures that must not be exceeded when cruising or when the engine is at a fixed rpm for a long period of time:

Exhaust gas temperature 550°C.

Temperature under the spark plug 170°C.

Temperatures that must not be exceeded when taking off and when all the power is required of the engine:

Exhaust gas temperature 580°C.

Temperature under the spark plug 200°C.

**WARNING!** The engine must NEVER, at any time or under any conditions, exceed:

580°C exhaust gas temperature (EGT)

200°C temperature under the spark plug (CHT)

It is therefore necessary to use a tool to read these temperatures, in order to protect the engine, and above all ensure the safety of yourself and others.

We also inform you that high exhaust gas temperatures, in many cases, are symptom of poor carburation. While high temperatures under the spark plug are due to poor heat dissipation of the engine, caused by high external temperatures or excessive propeller diameters, which cause poor air flow over the engine.

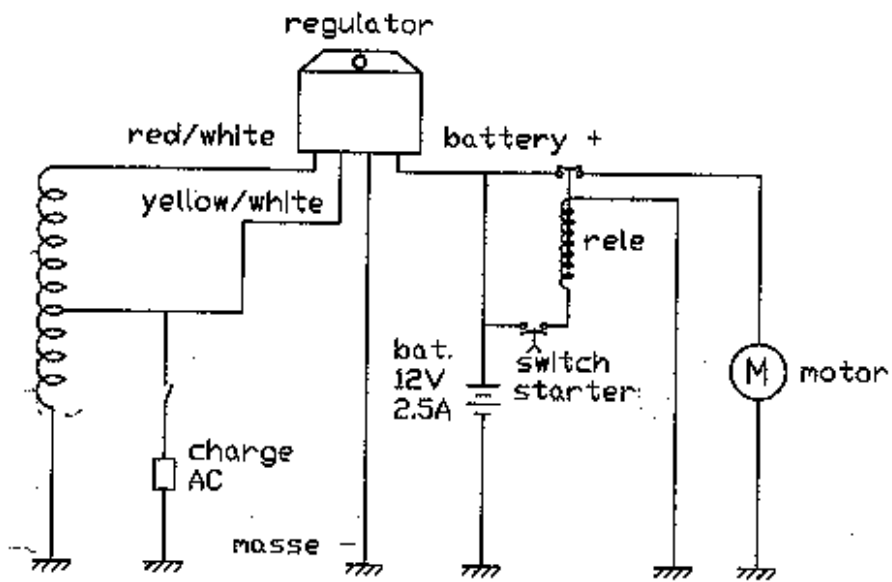
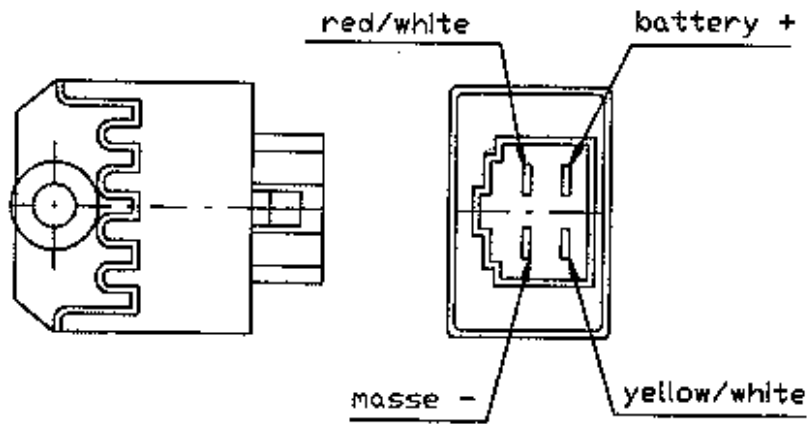

REQUESTS FOR REPAIRS OR REPLACEMENT OF COMPONENTS UNDER GUARANTEE

WARNING

THE GUARANTEE IS VALID FOR 12 MONTHS FROM THE PURCHASE DATE AND EXTENDS TO ALL THE ENGINE COMPONENTS (EXCLUDING COMPONENTS SUBJECT TO WEAR AND TEAR: NIKASIL FILLING OF THE CYLINDER, PISTON MANTLE AND TRANSMISSION BELT). THE GUARANTEE IS FORFEITED IF THE ENGINE HAS BEEN TAMPERED WITH OR IF ANY COMPONENTS HAVE NOT BEEN REPLACED WITH ORIGINAL PARTS OR PARTS THAT HAVE NOT BEEN APPROVED BY US.

THE COMPONENTS REPLACED UNDER GUARANTEE WILL BE COVERED FOR 12 MONTHS FROM THE DELIVERY DATE.

FOR ANY REPLACEMENT UNDER GUARANTEE, THE FAULTY COMPONENT MUST BE SENT BACK TO WALKERJET FACTORY, CARRIAGE PAID BY THE SENDER.

We would like to thank you for your custom, and remind you that the staff at WALKERJET are at your complete disposal for any queries or explanations.